

Electrical Surgical Bone Saws

instruction manual

Semi-Reusable

REF SP-002533

Model no : SMX2001-00

General Description

Ideal for use in orthopaedic osteotomies and other bone-cutting procedures. The Oscillating Saw provides constant power for the entire procedure. Ergonomic & lightweight design, allowing for optimal manoeuvrability and minimizing wrist fatigue. The Linvatec type's saw locking hub accepts standard oscillating saw blades. The Oscillating Saw comes in a sterile package, providing the user with the confidence of sterilization and availability when required.

Instructions for Use

1. Peel open the pack and remove all of the items.
2. Turn the knob to open saw blade locking hub, insert the saw blade and reverse knob to confirm the saw blade is completely fixed. **(A B)**

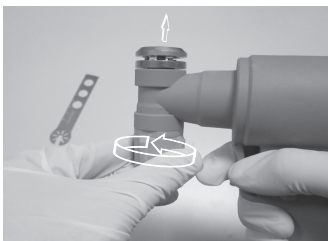

3. Sterile Person- Open the cover and put Transfer(Funnel) on the top. **(F G)**
4. Non-Sterile Person- Place battery pack and take the Transfer(Funnel) out of the battery box. **(H G)**
5. Sterile Person- Close the cover. **(F)**

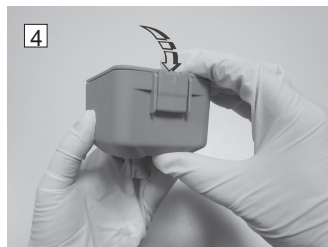

6. Install the battery box in the tool and secure connection.

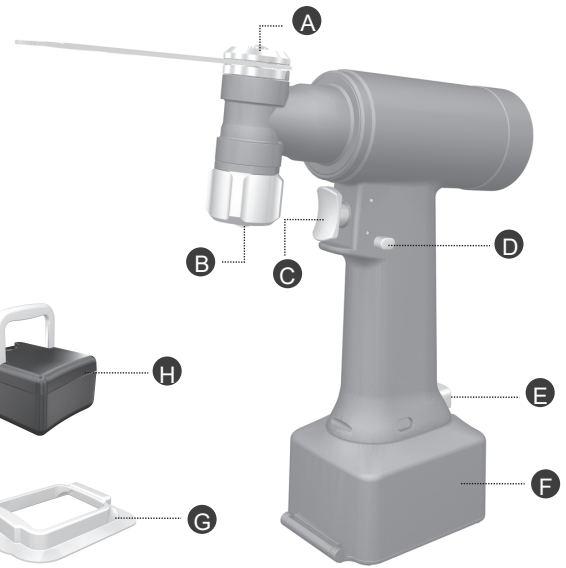
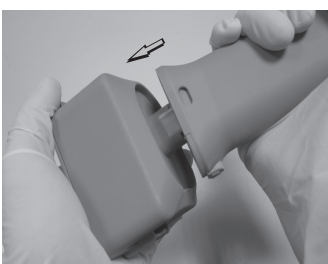

Read the operating instruction carefully before use. Failure to follow may cause damage or injuries.

7. Push switch to ON position **(D)**, depress Variable-Speed Trigger to operate handpiece. **(C)**

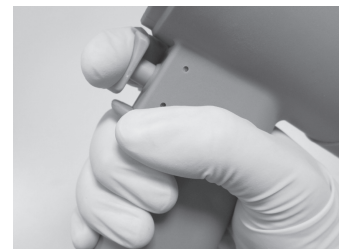
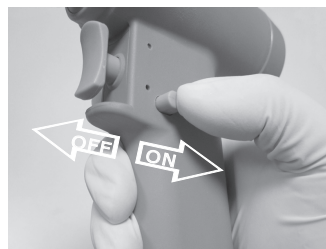

8. Battery Pack Removal:
 - Push switch to OFF mode **(D)**, depress the latch and slide battery pack out of the handpiece. **(E F)**
 - Always remove battery pack when not in use.

Saw Blade Compatible

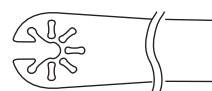

For LINVATEC / Hall

Specification

- 0-14,500 cycles per min
- Cutting ARC 4.0 degree
- Max Power 300W
- Weight 720 grams (hand piece only)
- Weight 1010 grams (hand piece with battery power)

Caution

International law restricts this device to sale by or on the order of a physician.

Warnings

Excessive heat is the most likely cause of patient injury. Any power instrument is subject to overheating, especially in the nose section. Even normal operation of the system in cycle other than 2 minutes "ON" and allowing the handpiece to cool to room temperature may cause the handpiece to become hot.

Power Input- By Power Console

1. Peel open the Power Cord pack and remove all of the items.
2. Ensure the power console switch at OFF position first , put power cord plug into bottom of hand piece power socket until the connection is secure.

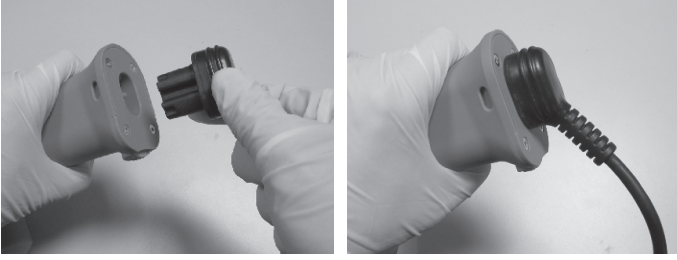

3. Put power cord another end plug into power console " " socket. Switch Power ON for ready the operation.



Battery Pack Charging

LED Indicator Signal Table

	STATUS (Red/Green LED)
Stand-by (Battery Pack Disconnected)	Constant Green
In Charging	Constant Red
Charging Completion	Constant Green
Charger Failed	Flash Red

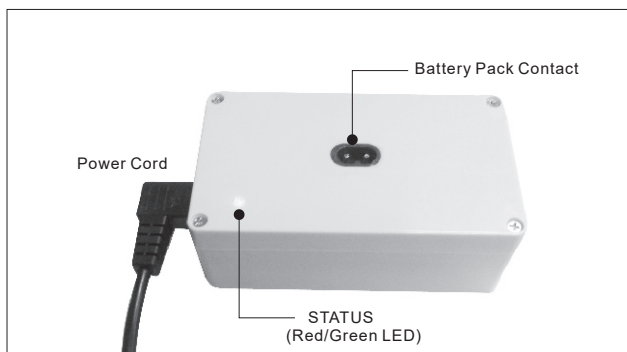

1. Plug one end of the AC power cord to charger first and then the other end of AC power cord to the electrical outlet. The power LED will turn into Green as the charger passes the power on test.
2. Connect the input of Li-Ion battery pack to the charger Contact. The Status LED will turn into constant RED and the charging starts.



3. The status LED will stay RED until battery pack is fully charged and when the charging is completed, the status indicator will turn GREEN.

First Time--Please charge battery pack until Charger turns green.

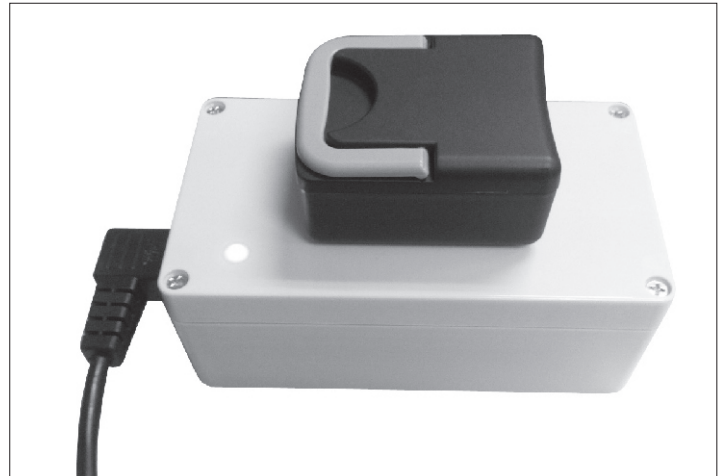

Charger Specifications

1. Input: 100~240VAC, 50/60 Hz.
2. Output : 12.6V 2A DC.
3. Charger output: The charger is preset by factory for charging 3 cells Li-Ion battery pack.

⚠ Caution:

1. Make sure battery pack is compatible with charger before connecting.
2. Never use this charger to charge a non-rechargeable battery.
3. DO NOT dispose battery in fire.























⚠ Warnings

- Sterile only if package is unopened and undamaged.
- Ensure that the device is disposed of safely and in accordance with all current national and international waste disposal directives.
- Store in a cool dry place.



Please dispose of the device in accordance with EC Directive – WEEE (Waste Electrical and Electronic Equipment).

Labeling Symbols

-  Refer to instruction manual/booklet
-  General warning sign / Caution
-  Do not use if package is damaged
-  Keep dry
-  Temperature limit
-  Sterilized using ethylene oxide
-  Complies with EU directives
-  Manufacturer
-  Premature unpacking warning
-  Type BF applied part
-  **MD** Medical Device
-  Direct current
-  **REF** Catalog number
-  Use by date
-  **LOT** Batch code
-  Date of manufacture
-  **S/N.** Serial number
-  Consult instructions for use
-  European Union WEEE Directive Logo
-  Recycle Li-ion battery
-  **EC REP** Authorized representative in the European Community
-  **UK RP** UK Responsible Person

Distributed by
Kaiser Medical Technology Ltd
Brinkworth House Business
Centre Brinkworth, Wiltshire,
SN15 5DF, UK

EC REP **MedNet EC-REP GmbH**
Borkstrasse 10, 48163 Muenster,
Germany.

UK RP **Medimap Ltd**
2 The Drift, Suffolk, Thurston,
IP31 3RT, United Kingdom

 **Dongguan Kaiser Technology Co., Ltd.**
No.6, 2nd Road, Sanjiang Industrial Block,
Hengli Town, Dongguan City, 523462
Guangdong P.R.China